

REV.	DESCRIPTION	DATE	BY

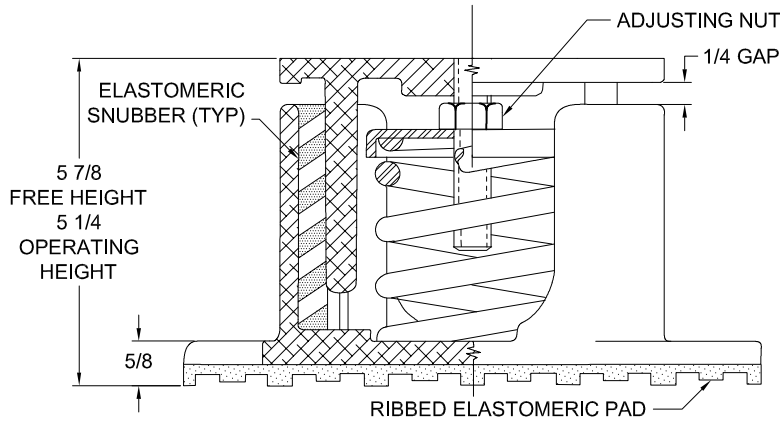
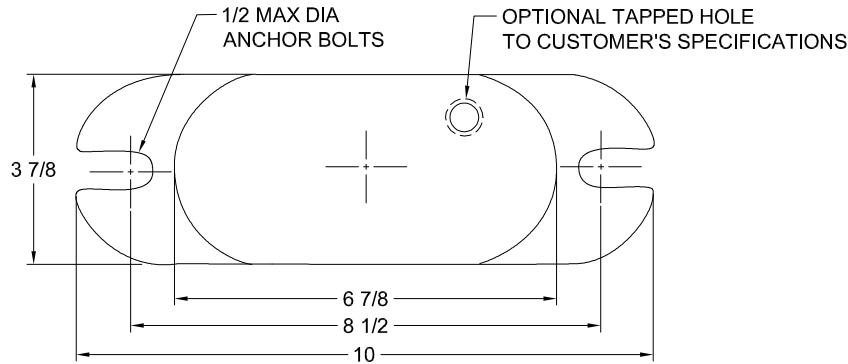

TYPE CALH-1E CAST ALUMINUM SPRING ISOLATORS FOR 1" NOMINAL DEFLECTION				
MODEL	MAX LOAD (LBS)	DEFLECTION (IN)	SPRING RATE (LB/IN)	SPRING COLOR CODE
CALH-1E-195	195	1.95	100	DK BLUE
CALH-1E-400	400	1.32	303	BLACK
CALH-1E-530N <sup>1</sup>	530	1.17	453	BLACK/ DK BLUE
CALH-1E-650	650	1.05	620	RED
CALH-1E-825N <sup>1</sup>	825	1.07	770	RED/ DK BLUE
CALH-1E-1000	1000	1.00	1000	TAN
CALH-1E-1200N <sup>1</sup>	1200	1.04	1150	TAN/ DK BLUE
CALH-1E-1400	1400	1.00	1400	PINK
CALH-1E-1700N <sup>1</sup>	1700	1.10	1550	PINK/ DK BLUE
CALH-1E-2000	2000	1.11	1800	WHITE
CALH-1E-2330N <sup>1</sup>	2330	1.11	2100	WHITE/ RED
CALH-1E-2575N <sup>1</sup>	2575	1.11	2313	WHITE/DK PURPLE
CALH-1E-2990N <sup>1</sup>	2990	1.12	2681	WHITE/DK GREEN
CALH-1E-3250N <sup>1</sup>	3250	1.04	3127	WHITE/GRAY

NOTES:

1. TWO NESTED SPRINGS YIELD THIS LOAD. THE COLOR CODE IS FOR OUTER SPRING/ INNER SPRING.

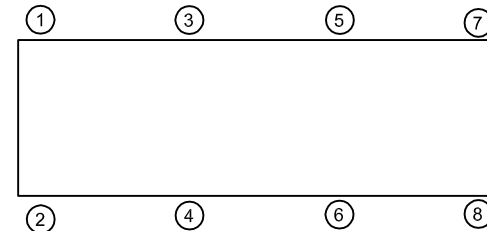

NOTES:

1. ALL DIMENSIONS ARE IN INCHES, INTERPRET PER ANSI Y14.
2. UNLESS OTHERWISE NOTED, DIMENSIONS FOR STYLE APPLY TO ALL OTHER STYLES.
3. FINISH: HOUSINGS-CAST ALUMINUM, SPRINGS-POWER COAT, HARDWARE- ZINC ELECTROPLATE.
4. REFER TO SHEET 2 OF 2 FOR INSTALLATION INSTRUCTIONS.
5. INNER SPRING (WHEN USED) NOT SHOWN.
6. ALL SPRINGS ARE DESIGNED WITH 50% OVER TRAVEL.
7. DETAILS NOT SHOWN ON OTHER VIEW FOR CLARITY.
8. RATED DEFLECTIONS ARE WITHIN 25% OF NOMINAL. HIGHER DEFLECTIONS ARE ALLOWED IF THEY MEET SPECIFICATIONS.

ISOLATOR SELECTIONS

LOC 1:	LOC 2:
LOC 3:	LOC 4:
LOC 5:	LOC 6:
LOC 7:	LOC 8:
CUSTOMER EQP'T. TAG:	

NOTE: MATERIAL SHOWN IS FOR (1) SET.

OTHER MATERIALS, COMPOUNDS, OR FINISHES WITH EQUAL OR SUPERIOR PROPERTIES MAY BE SUBSTITUTED AS THEY BECOME AVAILABLE.

CERTIFIED FOR:

JOB NAME: \_\_\_\_\_  
 CUSTOMER : \_\_\_\_\_  
 CUSTOMER P.O.: \_\_\_\_\_  
 SALES ORDER: \_\_\_\_\_

MODEL CALH-1E 195-3250 LBS.  
 ALUM. SPRING ISOLATORS SNUBBED  
 WITH INTERNAL ADJUSTMENT  
 1 INCH DEFLECTION



**THE VMC GROUP**  
*The Power of Together*  
 Bloomingdale, NJ 07403  
 Houston, TX 77041

SCALE :  
 NONE

SHEET:

DRAWING NO.:



REVISION

REV.	DESCRIPTION	DATE	BY

**READ INSTRUCTIONS IN THEIR ENTIRETY BEFORE BEGINNING.**

ALL VMC GROUP HOUSED ISOLATORS ARE SHIPPED ASSEMBLED AND IDENTIFIED BY SIZE (LOAD CARRYING CAPACITY) AND BY THE COLOR CODE ON THE SPRINGS. THE NORMAL INSTALLATION AND ADJUSTMENT OF THIS TYPE ISOLATOR IS AS FOLLOWS:



1. LOCATE THE ISOLATORS IN THEIR PROPER POSITION UNDER THE EQUIPMENT. SEE SUBMITTAL DATA, INSTALLATION DRAWINGS, OR OTHER CORRESPONDENCE FOR CORRECT LOCATION OF ISOLATORS WHEN DIFFERENT CAPACITY ISOLATORS ARE USED FOR UNEQUAL LOAD DISTRIBUTION. ISOLATORS SHOULD BE SET ON A FLAT, LEVEL SURFACE AT THE SAME ELEVATION. SHIMS, IF REQUIRED, SHOULD BE FULL SIZE.
2. BEFORE THE ISOLATORS ARE ADJUSTED, THE WEIGHT OF THE EQUIPMENT MAY CAUSE THE TOP PLATE TO COME TO REST ON THE HOUSING. THE ISOLATORS SHOULD BE ADJUSTED TO PROVIDE A MINIMUM CLEARANCE OF 1/4" BETWEEN THE TOP PLATE AND THE HOUSING.
3. COMPRESS THE SPRINGS BY TURNING THE ADJUSTING NUT "A" CLOCKWISE. START AT ONE ISOLATOR AND MAKE FOUR TURNS ON THE ADJUSTING NUT "A", MOVE TO THE NEXT ISOLATOR AND MAKE FOUR TURNS, ETC., UNTIL ALL ISOLATORS HAVE BEEN ADJUSTED FOUR TURNS. REPEAT THIS PROCEDURE UNTIL A 1/4" GAP IS OBTAINED BETWEEN TOP PLATE AND HOUSING.
4. CHECK THE LEVEL OF THE EQUIPMENT. THE EQUIPMENT MAY NOW BE LEVELED BY MAKING SMALL ADJUSTMENTS OF INDIVIDUAL ISOLATORS AT THE HIGH AND LOW POINTS.
5. AFTER THE EQUIPMENT IS LEVEL, VISUALLY CHECK EACH ISOLATOR TO MAKE SURE SPRING COILS ARE NOT CLOSED AND THERE IS SUFFICIENT CLEARANCE BETWEEN TOP PLATE AND HOUSING.

**NOTES:**

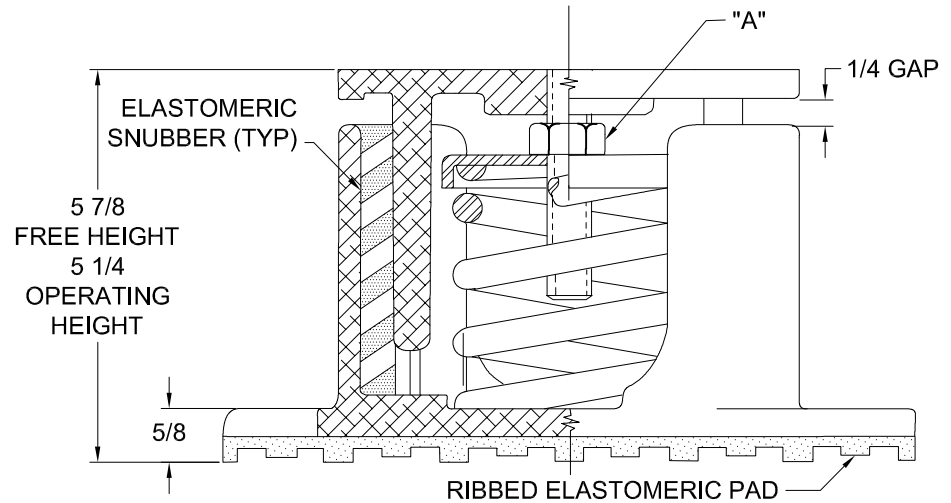
1. ALTHOUGH PROVISIONS HAVE BEEN MADE FOR ANCHOR BOLTS, THE NON-SKID ELASTOMERIC PAD ON THE BOTTOM OF THE ISOLATOR IS USUALLY SUFFICIENT TO PREVENT "WALKING" OF EQUIPMENT, AND NO BOLTING IS REQUIRED.
2. IF ISOLATOR MUST BE BOLTED TO SUPPORTING STRUCTURE, BOLTS SHOULD BE HAND-TIGHT. DO NOT OVER-TIGHTEN.



OTHER MATERIALS, COMPOUNDS, OR FINISHES WITH EQUAL OR SUPERIOR PROPERTIES MAY BE SUBSTITUTED AS THEY BECOME AVAILABLE.

<b>CERTIFIED FOR:</b> JOB NAME: _____ CUSTOMER : _____ CUSTOMER P.O.: _____ SALES ORDER: _____	<b>MODEL CALH-1E 195-3250 LBS.                  ALUM. SPRING ISOLATORS SNUBBED                  WITH INTERNAL ADJUSTMENT                  1 INCH DEFLECTION</b>	 <b>THE VMC GROUP</b> <i>The Power of Together</i> Bloomingdale, NJ 07403 Houston, TX 77041	SCALE : NONE	
			SHEET:	